

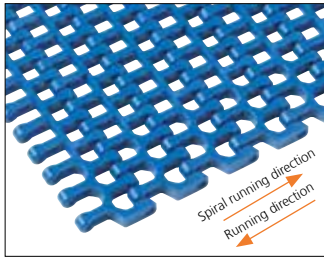

Plastic Modular Belt

Series uni Flex L-ASB



50% Open Radius 1.6

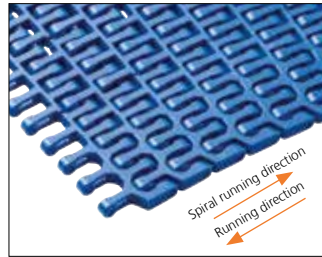

47% Open Radius 2.2

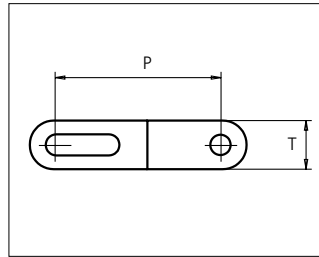

Sideflexing belt
 Nominal pitch: 50.8 mm (2.00 in)
 Surface type: Flat
 Surface opening: 47%/50%
 Backflex radius: 65.0 mm (2.56 in)
 Pin diameter: 6 mm (0.24 in)
 Min. inside radius: R1.6 x belt width, R2.2 x belt width



47/50% Open Rubber Top Radius 2.2

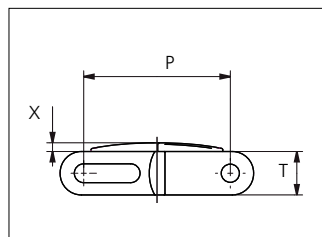

uni Flex L-ASB Rubber Top Radius 2.2: Indent min. 71.0 mm (2.80 in) and Increment 25.4 mm (1.00)
 uni Flex L-ASB Rubber Top R1.6: Indent min. 97.0 mm (3.82 in) and Increment 25.4 mm (1.00 in).

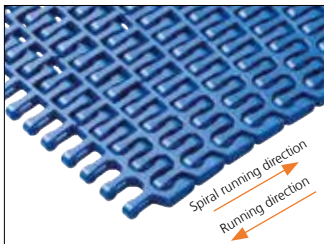

47% Open Tab Radius 2.2

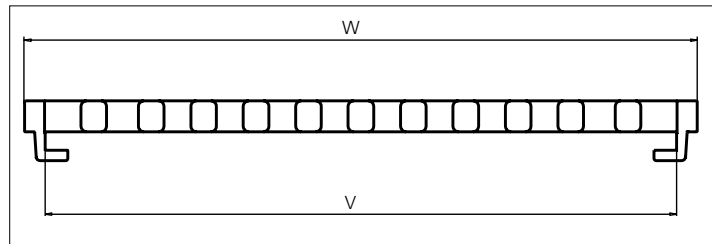
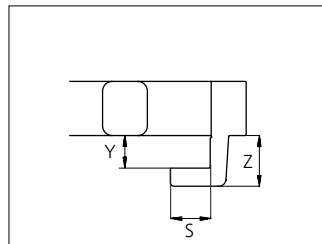

Type	Belt materials and colors	Pin materials and colors
47% Open Radius 2.2 47% Open Tab Radius 2.2 50% Open Radius 1.6	POM-D B W	PA6.6 B
	PP B	
47% Open Rubber Top Radius 2.2 47% Open Rubber Top Tab Radius 2.2 50% Open Rubber Top Radius 1.6	PP B + 03 K	

	mm	in		mm	in
P (Nominal)	50.8	2.00	W	325.9	12.83
S	11.0	0.43	X	3.0	0.12
T	15.0	0.59	Y	9.0	0.35
V	306.5	12.07	Z	14.0	0.55

Non standard material and color: See uni Material and Color Overview.

Alternative pin and lock materials:

🔧 Snap Pin A1: PP **W** PBT **LG** PA6.6 **B**

🔧 Lockpin: PBT **LG**



uni Flex L-ASB 50% Open Radius 1.6

Belt width		Permissible tensile force (Belt/pin material)								Belt weight (Belt/pin material)				*Min. No. drive sprocket per shaft	Number of wear strips (Min. No.)	
		POM-D/PA6.6				PP/PA6.6				POM-D/PA6.6		PP/PA6.6			**Carry (pcs)	**Return (pcs)
		Straight sections		Curve sections		Straight sections		Curve sections		kg/m	lb/ft	kg/m	lb/ft			
mm	in	N	lbf	N	lbf	N	lbf	N	lbf	kg/m	lb/ft	kg/m	lb/ft			
250	9.8	10000	2248	2440	549	5000	1124	1440	324	2.5	1.65	1.5	1.01	2	2	2
326	12.8	13040	2931	2440	549	6520	1466	1440	324	3.2	2.15	2.0	1.31	3	3	2
403	15.9	16120	3624	3110	699	8060	1812	1960	441	3.9	2.65	2.4	1.63	3	3	2
479	18.9	19160	4307	3110	699	9580	2154	1960	441	4.7	3.15	2.9	1.93	5	4	2
555	21.9	22200	4991	3110	699	11100	2495	1960	441	5.4	3.66	3.3	2.24	5	4	2
631	24.8	25240	5674	3110	699	12620	2837	1960	441	6.2	4.16	3.8	2.54	5	5	3
708	27.9	28320	6366	3110	699	14160	3183	1960	441	6.9	4.66	4.2	2.85	5	5	3
784	30.9	31360	7050	3110	699	15680	3525	1960	441	7.7	5.16	4.7	3.16	7	6	3
860	33.9	34400	7733	3110	699	17200	3867	1960	441	8.4	5.66	5.2	3.47	7	6	3
936	36.9	37440	8417	3110	699	18720	4208	1960	441	9.2	6.16	5.6	3.77	7	7	4
1013	39.9	40520	9109	3110	699	20260	4554	1960	441	9.9	6.67	6.1	4.08	7	7	4

Additional non-standard belt widths are available in steps of 25.4 mm (1.00 in).

General belt tolerance is +0/-0.4% at 23°C/73°F. For exact belt width contact Customer Service. Non standard belt width on request.

*Max. Load per Drive Sprocket. Belt material: POM-D 2500 N (562 lbf), PP 1200 N (270 lbf).

**Max. Spacing between wear strips, Carry: 152 mm (6 in); Return: 304 mm (12 in).

 = Single Link

uni Flex L-ASB 47% Open Radius 2.2

Belt width		Permissible tensile force (Belt/pin material)								Belt weight (Belt/pin material)				*Min. No. drive sprocket per shaft	Number of wear strips (Min. No.)	
		POM-D/PA6.6				PP/PA6.6				POM-D/PA6.6		PP/PA6.6			**Carry (pcs)	**Return (pcs)
		Straight sections		Curve sections		Straight sections		Curve sections		kg/m	lb/ft	kg/m	lb/ft			
mm	in	N	lbf	N	lbf	N	lbf	N	lbf	kg/m	lb/ft	kg/m	lb/ft			
250	9.8	10000	2248	2440	549	5000	1124	1440	324	2.5	1.65	1.5	1.01	2	2	2
326	12.8	13040	2931	2440	549	6520	1466	1440	324	3.2	2.15	2.0	1.31	3	3	2
403	15.9	16120	3624	3110	699	8060	1812	1960	441	3.9	2.65	2.4	1.63	3	3	2
479	18.9	19160	4307	3110	699	9580	2154	1960	441	4.7	3.15	2.9	1.93	5	4	2
555	21.9	22200	4991	3110	699	11100	2495	1960	441	5.4	3.66	3.3	2.24	5	4	2
631	24.8	25240	5674	3110	699	12620	2837	1960	441	6.2	4.16	3.8	2.54	5	5	3
708	27.9	28320	6366	3110	699	14160	3183	1960	441	6.9	4.66	4.2	2.85	5	5	3
784	30.9	31360	7050	3110	699	15680	3525	1960	441	7.7	5.16	4.7	3.16	7	6	3
860	33.9	34400	7733	3110	699	17200	3867	1960	441	8.4	5.66	5.2	3.47	7	6	3
936	36.9	37440	8417	3110	699	18720	4208	1960	441	9.2	6.16	5.6	3.77	7	7	4
1013	39.9	40520	9109	3110	699	20260	4554	1960	441	9.9	6.67	6.1	4.08	7	7	4
1089	42.9	43560	9792	3110	699	21780	4896	1960	441	10.7	7.17	6.5	4.39	9	8	4

Additional standard belt widths are available in steps of 76.2 mm (3.00 in) Additional non-standard belt widths are available in steps of 25.4 mm (1.00 in)

1699	66.9	67960	15277	3110	699	33980	7639	1960	441	16.7	11.19	10.2	6.85	13	12	6
------	------	-------	-------	------	-----	-------	------	------	-----	------	-------	------	------	----	----	---

Additional standard belt widths are available in steps of 76.2 mm (3.00 in) Additional non-standard belt widths are available in steps of 25.4 mm (1.00 in)

1927	75.9	77080	17328	3110	699	38540	8664	1960	441	18.9	12.69	11.6	7.77	13	13	7
------	------	-------	-------	------	-----	-------	------	------	-----	------	-------	------	------	----	----	---

General belt tolerance is +0/-0.4% at 23°C/73°F. For exact belt width contact Customer Service. Non standard belt width on request.

*Max. Load per Drive Sprocket. Belt material: POM-D 2500 N (562 lbf), PP 1200 N (270 lbf).

**Max. Spacing between wear strips, Carry: 152 mm (6 in); Return: 304 mm (12 in).

 = Single Link

Design Guidelines

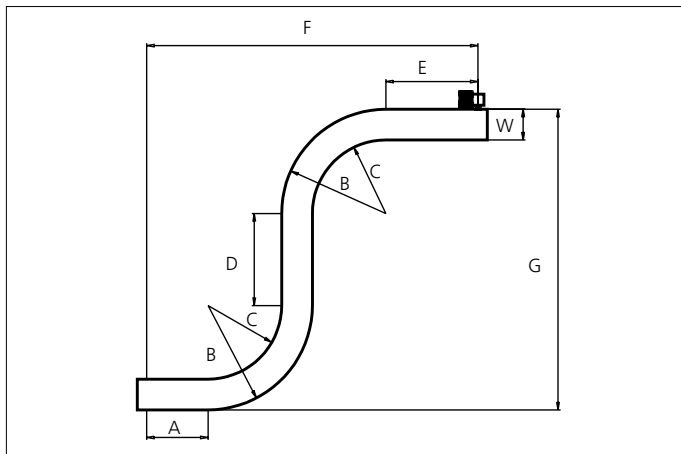

	47% Open Radius 2.2 47% Open Radius 2.2	50% Open Radius 1.6 (inside)
A	min. 1.5 x W	min. 1.5 x W
B	min. 3.2 x W	min. 2.6 x W
C	min. 2.2 x W	min. 1.6 x W
D	min. 2.0 x W	min. 2.0 x W
E	min. 2.0 x W	min. 2.0 x W
F	min. 8.9 x W	min. 7.7 x W
G	min. 8.4 x W	min. 7.2 x W

uni Flex L-ASB R1.6 can not be used in S-conveyors.

Accessories

Side Guard



Side Guard Open

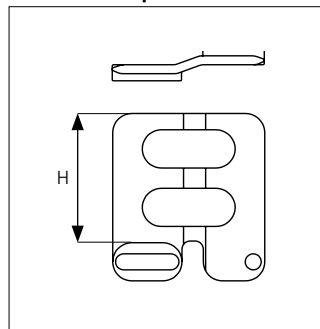

Side Guard

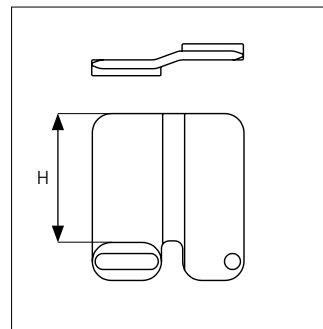

Type	Side Guard Material & color	H	
		mm	in
Side Guard	POM-D B W	10.0	0.39
		25.4	1.00
		50.0	1.97
Side Guard Open		50.0	1.97

* Min. indent for Side Guard is: 80.0 mm (3.15 in) and Increment 25.4 mm (1.00 in)
Non Standard material and color: See uni Material and Color Overview.

Accessories

AmFlight

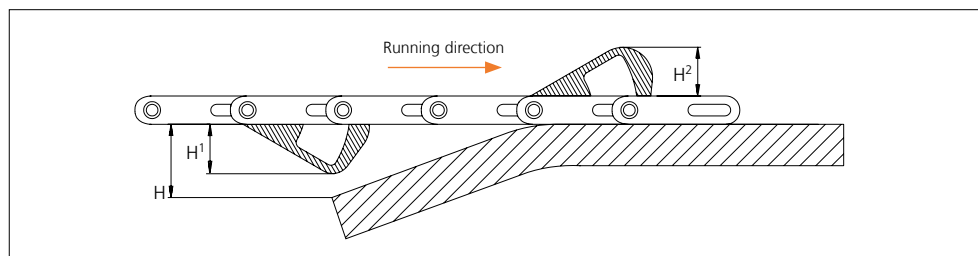
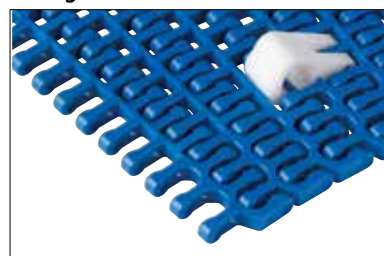

Type	Material & color	H	H ¹		H ²	
			mm	in	mm	in
AmFlight	PE W	H > H ¹	25.4	1.00	26.0	1.02

Other Non Standard option: See uni AmFlight Overview.

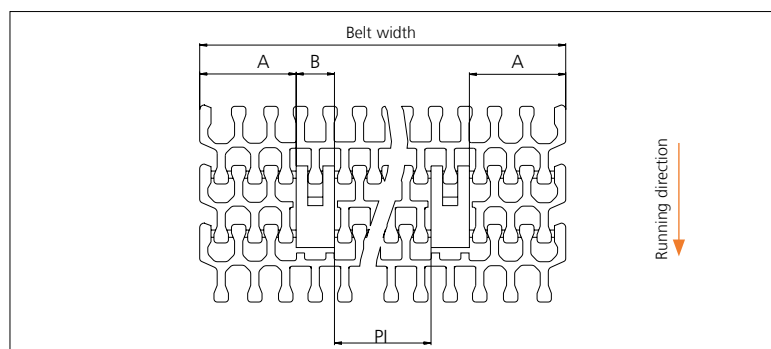

	mm	in
A min	83.0	3.27
B	33.0	1.30
PI min	68.5	2.70

Increment: 25.4 mm (1.00 in)

Accessories

Rubber Top

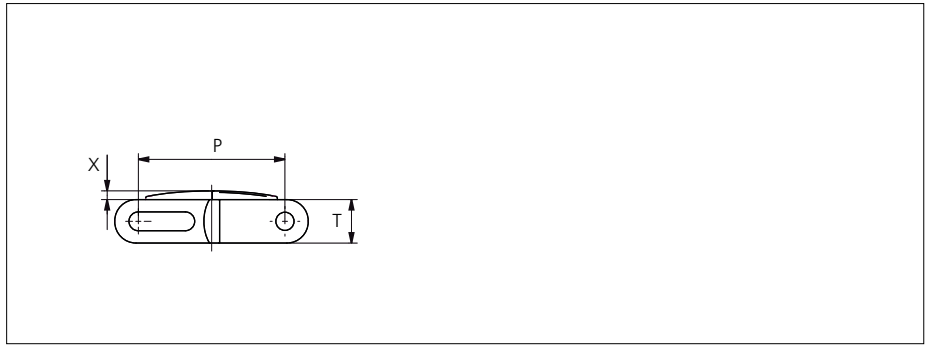
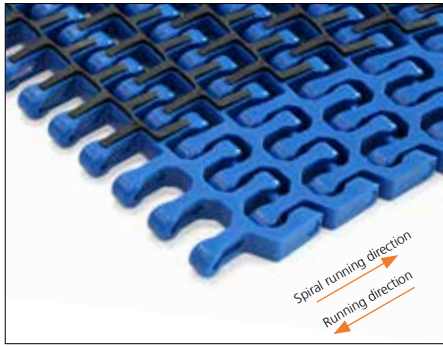

Type	Recommended belt materials and colors	Recommended pin materials and colors	P		T		X	
			mm	in	mm	in	mm	in
47% Open Rubber Top Radius 2.2 47% Open Rubber Top Tab Radius 2.2 50% Open Rubber Top Radius 1.6	PP B + 03 K	PA6.6 B	50.8	2.00	15.0	0.59	3.0	0.12

uni Flex L-ASB Rubber Top Radius 2.2: Indent min. 71.0 mm (2.80 in) and Increment 25.4 mm (1.00).

uni Flex L-ASB Rubber Top R1.6: Indent min. 97.0 mm (3.82 in) and Increment 25.4 mm (1.00 in).

Accessories

Side Guard



Side Guard Open

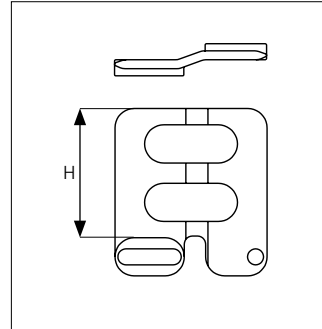

Side Guard

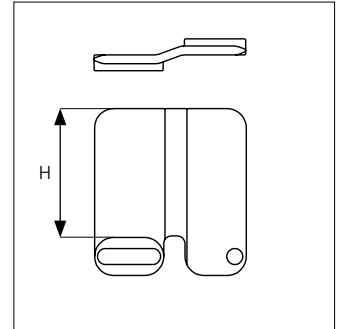

Side Guard Outside Only



Side Guard Outside Only

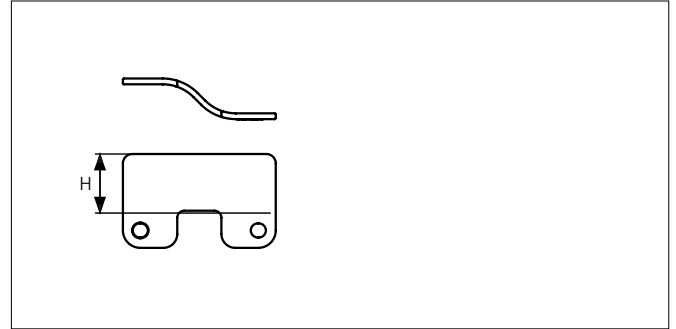

Type	Recommended Material & color	H	
		mm	in
Side Guard	POM-D B	10.0	0.39
Side Guard Open		25.4	1.00
Side Guard Outside Only		50.0	1.97
		50.0	1.97
		25.4	1.00

* Min. indent for Side Guard is: 80.0 mm (3.15 in) and Increment 25.4 mm (1.00 in)

Non Standard material and color: See uni Material and Color Overview.

